

PARTS

VARIOUS PARTS FOR STAY-ASSEMBLING

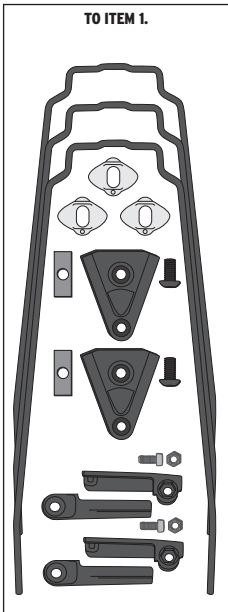

VARIOUS PARTS FOR MOUNTING THE FENDERS

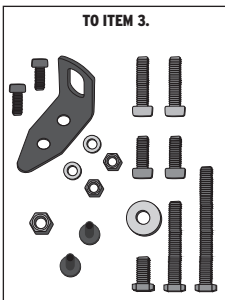
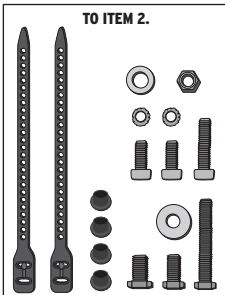

SPACERS FOR:
- FORKS WITH DISC BRAKES
- FRAME MOUNTING REAR
OPTIONAL



ATTENTION!

KEEP THE MINIMUM DISTANCE OF 15 MM BETWEEN FENDER AND TYRE.

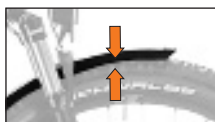

1. STAY-ASSEMBLING FRONT + REAR

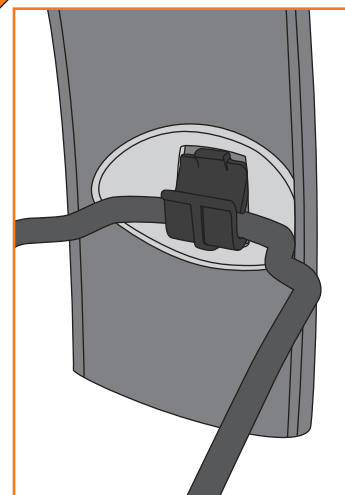
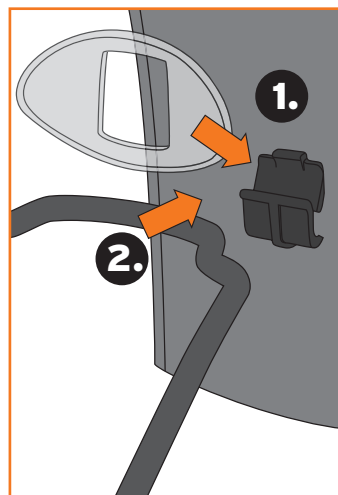
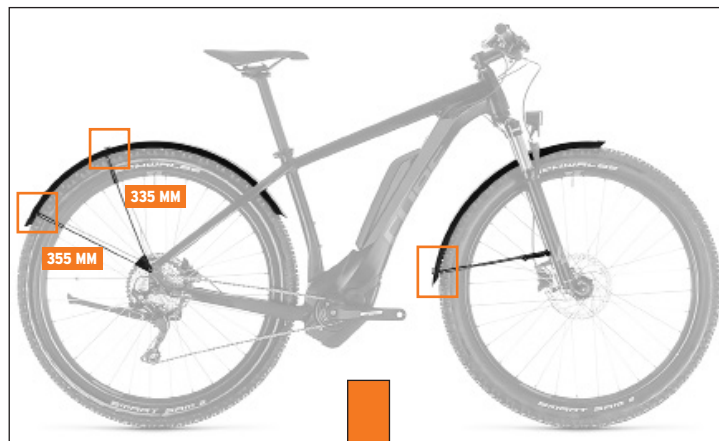
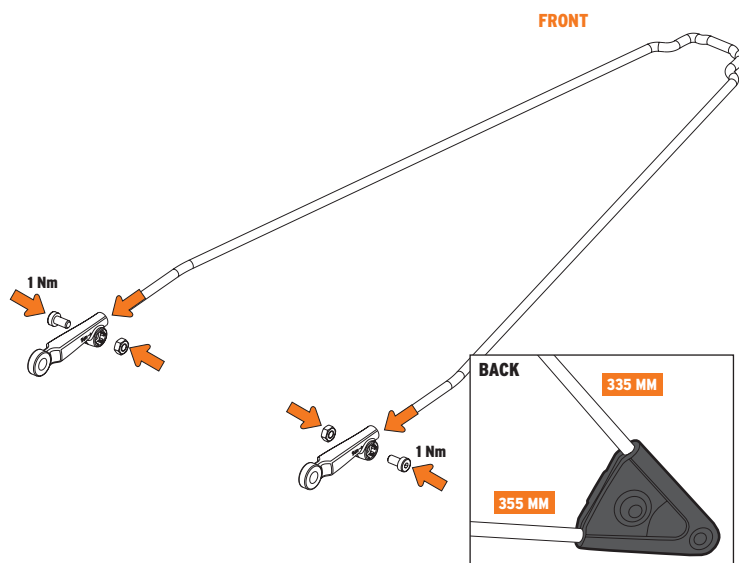

EN. BLUEMELS 75 U LONG

Proprietary construction, in which super-fine aluminium strips are embedded in a matte black plastic coating make these mudguards extremely durable, resistant to bending and UV damage.



2. FRAME MOUNTING FRONT

2.1 MOUNTING THE FRONT PLUGS

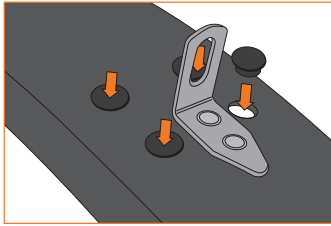

2.1.1 BRACKET-FITTING FRONT

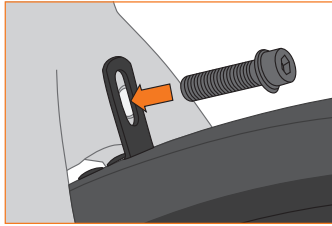

2.2 OPTIONAL FITTING STRAPS FRONT

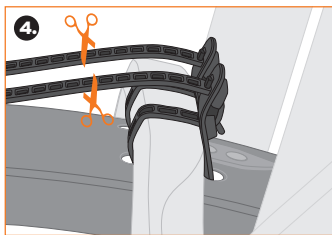
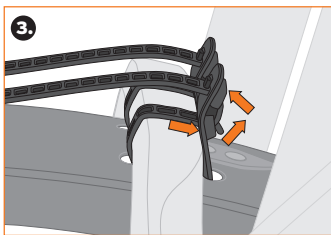
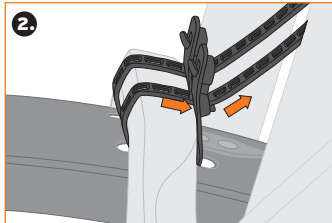
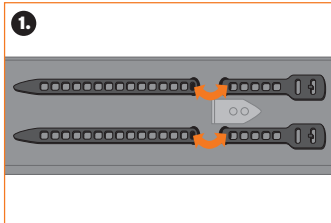

2.3 STAY ATTACHMENT FRONT INCL. LENGTHS ADJUSTMENTS OF THE STAYS

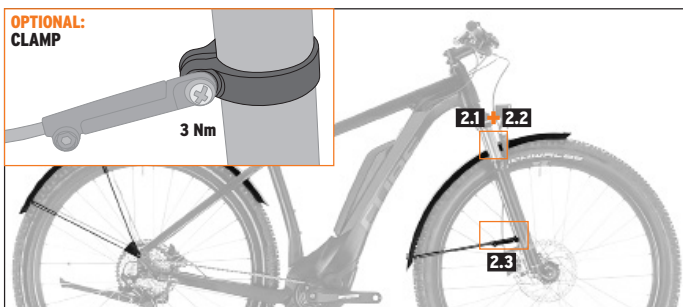
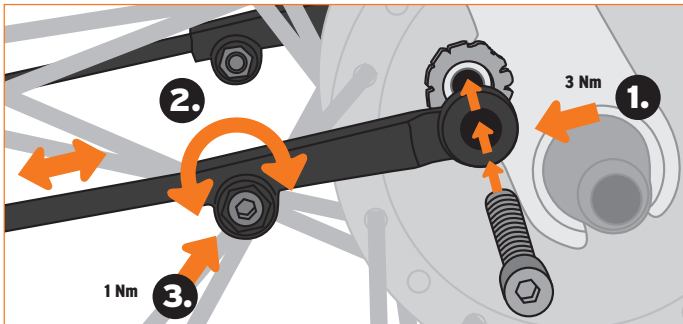

ADDITIONAL ASSEMBLY WITH: BLUEMELS 75 U LONG

3.6 TRETLAGERMONTAGE · MOUNTING AT THE BOTTOM BRACKET

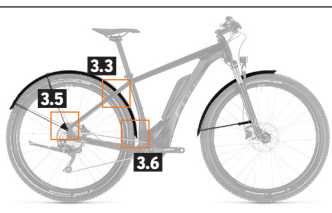
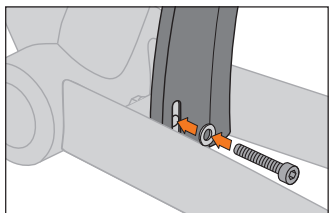

3. FRAME MOUNTING REAR

3.1 REMOVE THE REAR WHEEL

3.2 MOUNTING THE REAR MUDGUARD ONTO THE FRAME DIRECT BY SCREWING IT ON AT AN ANGLE OF 0°

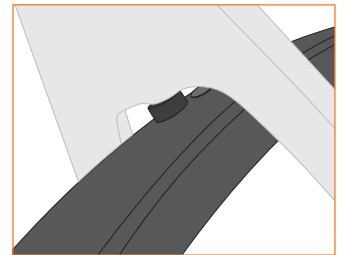
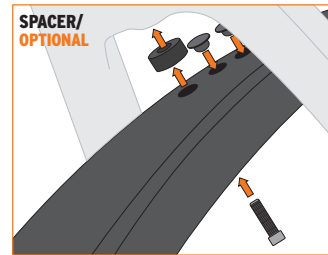

3.3 MOUNTING WITH AN ANGLE OF 90°

3.3.1 SCREW THE BRACKET

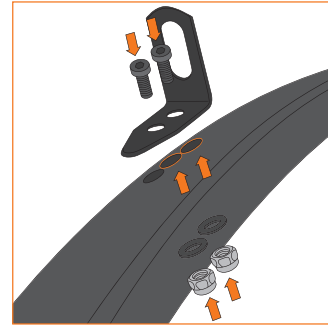

3.3.2 SCREW THE FENDER ON THE FRAME



3.4 REMOUNT THE REAR WHEEL

3.5 REAR STAY ASSEMBLING

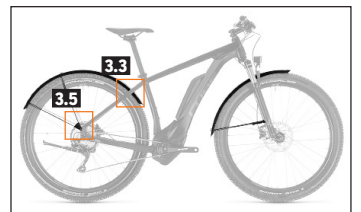
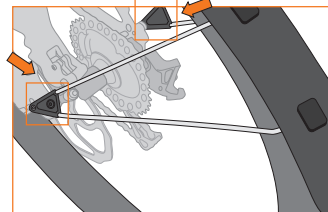

3.5.1 STAY ATTACHMENT REAR INCL. LENGTHS ADJUSTMENTS OF THE STAYS

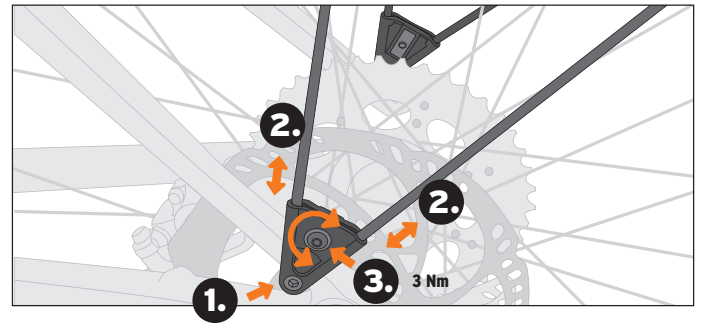

ATTENTION OPTIONAL! MOUNTING OF SPACERS FOR FRAMES WITH DISC BRAKES

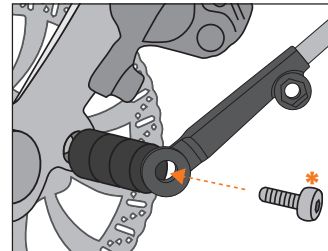

* SCREW IS NOT INCLUDED IN THE SCOPE OF DELIVERY